

ALUMINUM BEAM

Aluminum Beam

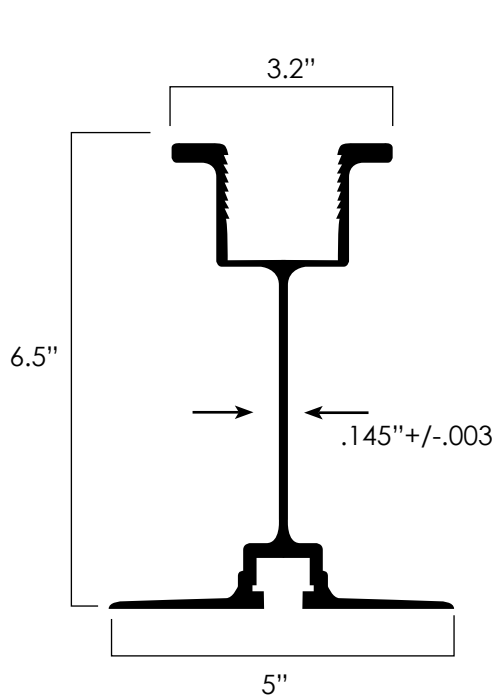

Aluminum Stringer

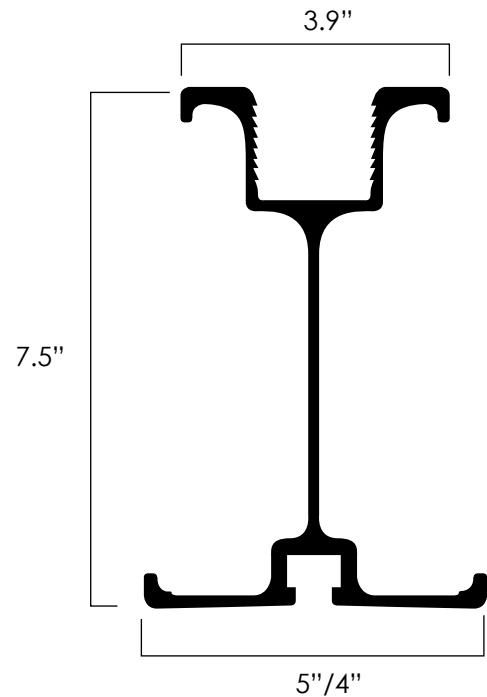

DESCRIPTION	WIDTH / LENGTH		WEIGHT	
	metric	imperial	metric	imperial
Aluminum Beam/per ft	.2 m	6.5"	1.82 kg/.31 m	3.2 lbs/ft
Aluminum Stringer/per ft	.31 m	7.5"	1.9 kg/.31 m	4.17 lbs/ft
Aluminum Beam	.2 m x 2.44 m	6.5" x 8"	14.55 kg	32 lbs
Aluminum Beam	.2 m x 3.05 m	6.5" x 10"	18.18 kg	40 lbs
Aluminum Beam	.2 m x 3.66 m	6.5" x 12"	21.82 kg	48 lbs
Aluminum Beam	.2 m x 4.27 m	6.5" x 14"	25.45 kg	56 lbs
Aluminum Beam	.2 m x 4.57 m	6.5" x 15"	27.27 kg	60 lbs
Aluminum Beam	.2 m x 4.88 m	6.5" x 16"	29.09 kg	64 lbs
Aluminum Beam	.2 m x 5.49 m	6.5" x 18"	32.73 kg	72 lbs
Aluminum Beam	.2 m x 6.1 m	6.5" x 20"	36.36 kg	80 lbs
Aluminum Beam	.2 m x 6.4 m	6.5" x 21"	38.18 kg	84 lbs
Aluminum Beam	.2 m x 6.71 m	6.5" x 22"	40 kg	88 lbs
Aluminum Beam	.2 m x 7.32 m	6.5" x 24"	43.64 kg	96 lbs
Aluminum Beam	.2 m x 7.62 m	6.5" x 25"	45.45 kg	100 lbs



*custom sizes available upon request

ALUMINUM BEAM

6.5" Aluminum Beam

Engineering Specifications

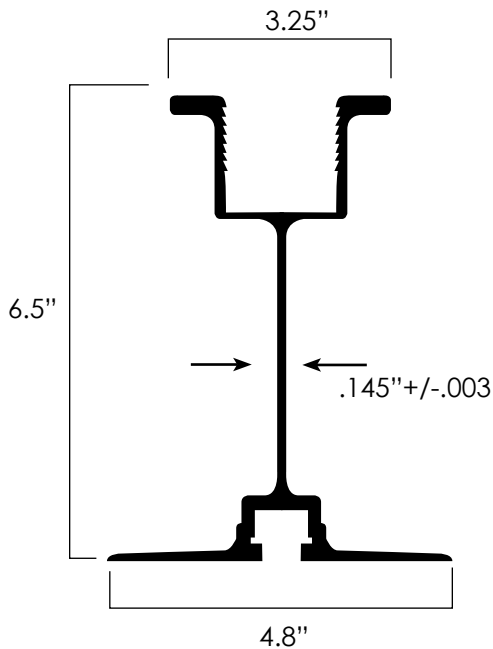

SECTION PROPERTIES

Cross Section Area		2.76 in ²
Nominal Weight (incl. nailer)		4 lbs/ft
Moment of Inertia	I _x	17.84 in ⁴
	I _y	2.71 in ⁴
Section Modules	S _{xt}	5.07 in ³
	S _{xb}	5.92 in ³
	S _y	1.13 in ³
Radius of Gyration	r _x	2.54 in
	r _y	0.99 in

Loading chart for access application only
Not to be used for shoring applications

Span (ft)	Load (plf)
3	2500
4	2500
5	1660
6	150
7	845
8	650
9	510

Span (ft)	Load (plf)
10	415
11	345
12	290
13	245
14	200
15	160
16	120

Note: Above loads are based on a safety factor of 4-1 in bending and a maximum deflection of 1" at the center of the span.

ALUMINUM BEAM

7.5" Aluminum Stringer

Engineering Specifications

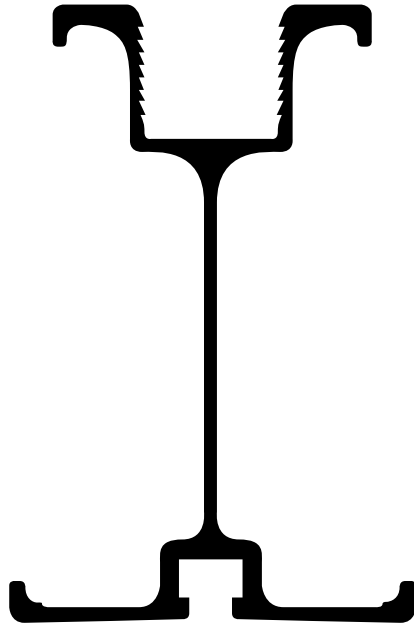

SECTION PROPERTIES

Cross Section Area		3.55 in ²
Nominal Weight (incl. nailer)		4.6 lbs/ft
Moment of Inertia	lx	30.92 in ⁴
	ly	2.28 in ⁴
Section Modules	sxt	8.25 in ³
	sxb	8.25 in ³
Radius of Gyration	r _x	2.95 in
	r _y	0.80 in

Span (ft)	Load (plf)
4	2500
5	1660
6	150
7	845

Span (ft)	Load (plf)
8	880
9	560
10	380
11	275

Note: Above loads are based on a safety factor of 2-2 in bending and a deflection limited to the lesser of 3/8".

For other applications, please consult our engineering department.



*custom sizes available upon request